

Features

- High flow/high-pressure bodies with manual reset to prevent inadvertent valve start-up
- Once tripped, can only be manually reset
- Electrically Tripped (trips when energized), No Voltage Release (trips when de-energized), or Free Handle constructions
- Available for Latched Open or Latched Closed operation
- Ideal for controlling critical processes
- Some constructions can control aggressive fluids, including steam
- Intrinsically Safe constructions are available
See Pilot Valve Section for details

Construction

Valve Parts in Contact with Fluids		
Body	Brass	Stainless Steel
Stem	303 Stainless Steel	
Springs	302 Stainless Steel	
Pilot Seat Cartridge	CA (when listed)	
Disc, Diaphragm, Seat	NBR, PA, PTFE, or Stainless Steel, as listed	

Electrical

Standard Coil and Class of Insulation	Watt Rating and Power Consumption				Spare Coil Part Number	
	DC Watts	AC			AC	DC
		Watts	VA Holding	VA Inrush		
F	-	20	45	96	99257	-
H	36.2	-	-	-	-	222184

Standard Voltages: 24, 120, 240, 480 volts AC, 60 Hz. 6, 12, 24, 120, 240 volts DC. Must be specified when ordering. Other voltages are available when required.

Notes: 125 and 250 volts DC are battery voltages applied in power plants. Special valves are available to pilot control valves in power plants.

Consult your local ASCO sales office for a listing.

Solenoid Enclosures

Standard: RedHat metal solenoid enclosure.
Type 1 General Purpose Junction Box.

Optional: Explosionproof and Watertight, Types 3, 7 (C and D), and 9.
(To order, add prefix "EF" to catalog number.)

See Optional Features Section for other available options.

Nominal Ambient Temp. Ranges

AC: -20°F to 104°F (-29°C to 40°C)

DC: -20°F to 77°F (-29°C to 25°C)

Refer to Engineering Section for details.

Approvals

CSA certified. Some constructions meet shock and vibration ISA S71.03C2.

Refer to Engineering Section for details.

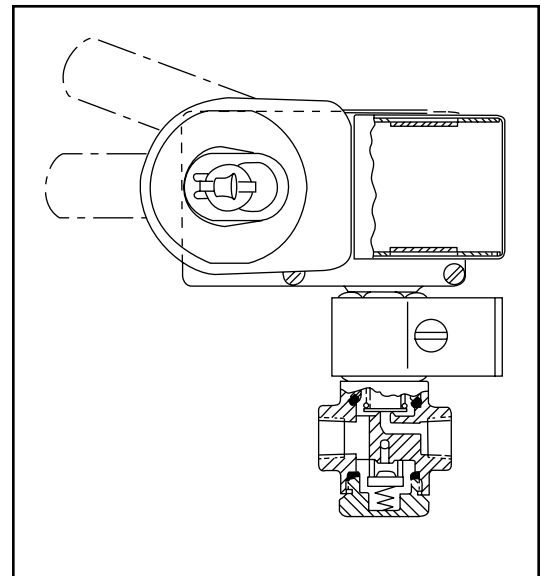
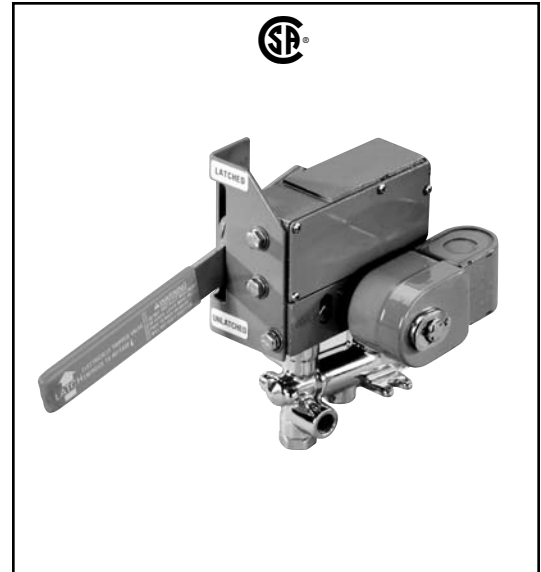

SPECIAL SERVICE PILOT

Operation Alternatives

Electrically Tripped – Manually move the lever to the latched position with the solenoid de-energized. Trips when solenoid is energized. Once tripped, the lever may be cycled causing the valve discs to open and close.

No Voltage Release – Manually move the lever to the latched position with the solenoid energized. Trips when solenoid is de-energized. Once tripped, the lever may be cycled causing the valve discs to open and close.

Free Handle – Solenoid must be energized before the lever can engage and be manually moved to the latched position. While engaged, lever may be cycled causing the valve discs to open and close. Will trip instantly when solenoid is de-energized.

Specifications (English units)

Pipe Size (ins.)	Orifice Size (ins.)	Cv Flow Factor	Operating Pressure Differential (psi)			Max. Fluid Temp. °F		No Voltage Release Catalog Number	Electrically Tripped Catalog Number	Const. Ref.	Flow Diagram	Watt Rating/Class of Coil Insulation	
			Min.	Max. AC	Max. DC	AC	DC					AC	DC
UNIVERSAL OPERATION (Except as Noted ①), Brass Body with NBR Disc/Diaphragm (CA Pilot Cartridge) for Air-Inert Gas and Water. This group of valves meets shock and vibration ISA S71.03C2.													
1/4	11/64	.38	0	125	125	180	180	8308B040	8310B040	1	B	20/F	36.2/H
3/8	5/8	3	10	250	250	180	180	8308C041 ① ②	8310C041 ① ②	2	C	20/F	36.2/H
1/2	5/8	4	10	250	250	180	180	8308C042 ① ②	8310C042 ① ②	2	C	20/F	36.2/H
3/4	11/16	5.5	10	250	250	180	180	8308C043 ① ②	8310C043 ① ②	3	C	20/F	36.2/H
1	1	13	10	125	125	180	180	8308A050 ① ②	8310A050 ① ②	8	C	20/F	36.2/H
UNIVERSAL OPERATION, Brass Body with Stainless Steel Seats and Discs for Air-Inert Gas, Water and Light Oil													
1/4	1/4	.45	0	125	125	200	200	8308044	8310044	4	A	20/F	36.2/H
3/8	1/4	.45	0	125	125	200	200	8308045	8310045	4	A	20/F	36.2/H
1/2	5/16	.75	0	125	125	200	200	8308046	8310046	5	A	20/F	36.2/H
UNIVERSAL OPERATION, Brass Body with NBR Seats and PA Discs for Air-Inert Gas, Water and Light Oil													
1/4	1/4	.39	0	125	125	180	180	8308044R	8310044R	4	A	20/F	36.2/H
3/8	1/4	.39	0	125	125	180	180	8308045R	8310045R	4	A	20/F	36.2/H
1/2	5/16	.53	0	125	125	180	180	8308046R	8310046R	5	A	20/F	36.2/H
UNIVERSAL OPERATION, Stainless Steel Body with FKM Discs for Air-Inert Gas and Water													
1/4	1/8	.21	0	125	125	180	180	8308A011	8310A011	1	B	20/F	36.2/H
UNIVERSAL OPERATION, Stainless Steel Body with Stainless Steel Seats and Discs for Corrosive Service													
1/2	5/16	.75	0	125	125	200	200	8308047	8310047	5	A	20/F	36.2/H
Free Handle Construction													
UNIVERSAL OPERATION, Brass Body with NBR Discs for Air-Inert Gas and Water													
1/4	11/64	.38	0	125	125	180	180	8037014		6	D	20/F	36.2/H
UNIVERSAL OPERATION, Brass Body with PTFE Seats and FKM Discs for Air-Inert Gas, Water and Light Oil													
1/4	3/16	.70	0	125	125	160	160	8037A008 ①		7	E	20/F	36.2/H
3/8	3/16	.70	0	125	125	160	160	8037A010 ①		7	E	20/F	36.2/H
UNIVERSAL OPERATION, Stainless Steel Body with FKM Discs for Air-Inert Gas and Water													
1/4	1/8	.21	0	125	125	180	180	8037012		6	D	20/F	36.2/H

① When ordering, specify suffix "F" for Normally Closed construction or Suffix "G" for Normally Open construction. ② Supplied with CA pilot cartridge.

Specifications (Metric units)

Pipe Size (ins.)	Orifice Size (mm)	Kv Flow Factor (m3/h)	Operating Pressure Differential (bar)			Max. Fluid Temp. °C		No Voltage Release Catalog Number	Electrically Tripped Catalog Number	Const. Ref.	Flow Diagram	Watt Rating/Class of Coil Insulation	
			Min.	Max. AC	Max. DC	AC	DC					AC	DC
UNIVERSAL OPERATION (Except as Noted ①), Brass Body with NBR Disc/Diaphragm (CA Pilot Cartridge) for Air-Inert Gas and Water. This group of valves meets shock and vibration ISA S71.03C2.													
1/4	4	.33	0.0	9	9	82	82	8308B040	8310B040	1	B	20/F	36.2/H
3/8	16	2.57	0.7	17	17	82	82	8308C041 ① ②	8310C041 ① ②	2	C	20/F	36.2/H
1/2	16	3.43	0.7	17	17	82	82	8308C042 ① ②	8310C042 ① ②	2	C	20/F	36.2/H
3/4	17	4.71	0.7	17	17	82	82	8308C043 ① ②	8310C043 ① ②	3	C	20/F	36.2/H
1	25	11.14	0.7	9	9	82	82	8308A050 ① ②	8310A050 ① ②	8	C	20/F	36.2/H
UNIVERSAL OPERATION, Brass Body with Stainless Steel Seats and Discs for Air-Inert Gas, Water and Light Oil													
1/4	6	.39	0	9	9	93	93	8308044	8310044	4	A	20/F	36.2/H
3/8	6	.39	0	9	9	93	93	8308045	8310045	4	A	20/F	36.2/H
1/2	8	.64	0	9	9	93	93	8308046	8310046	5	A	20/F	36.2/H
UNIVERSAL OPERATION, Brass Body with NBR Seats and PA Discs for Air-Inert Gas, Water and Light Oil													
1/4	6	.33	0	9	9	82	82	8308044R	8310044R	4	A	20/F	36.2/H
3/8	6	.33	0	9	9	82	82	8308045R	8310045R	4	A	20/F	36.2/H
1/2	8	.45	0	9	9	82	82	8308046R	8310046R	5	A	20/F	36.2/H
UNIVERSAL OPERATION, Stainless Steel Body with FKM Discs for Air-Inert Gas and Water													
1/4	8	.18	0	9	9	82	82	8308A011	8310A011	1	B	20/F	36.2/H
UNIVERSAL OPERATION, Stainless Steel Body with Stainless Steel Seats and Discs for Corrosive Service													
1/2	8	.64	0	9	9	93	93	8308047	8310047	5	A	20/F	36.2/H
Free Handle Construction													
UNIVERSAL OPERATION, Brass Body with NBR Discs for Air-Inert Gas and Water													
1/4	4	.33	0	9	9	82	82	803714		6	D	20/F	36.2/H
UNIVERSAL OPERATION, Brass Body with PTFE Seats and FKM Discs for Air-Inert Gas, Water and Light Oil													
1/4	5	.60	0	9	9	71	71	8037A008 ①		7	E	20/F	36.2/H
3/8	5	.60	0	9	9	71	71	8037A010 ①		7	E	20/F	36.2/H
UNIVERSAL OPERATION, Stainless Steel Body with FKM Discs for Air-Inert Gas and Water													
1/4	3	.18	0	9	9	82	82	8037012		6	D	20/F	36.2/H

Flow Diagrams

Electrically Tripped and No Voltage Release Constructions

Flow Diagram A

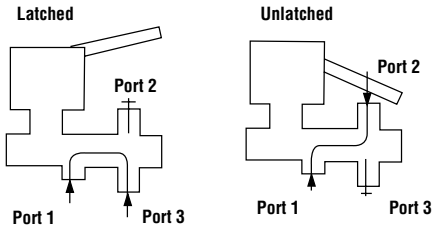

Flow Diagram B

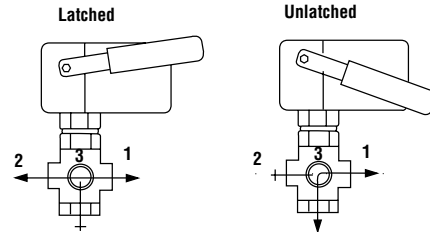

Flow Diagram C

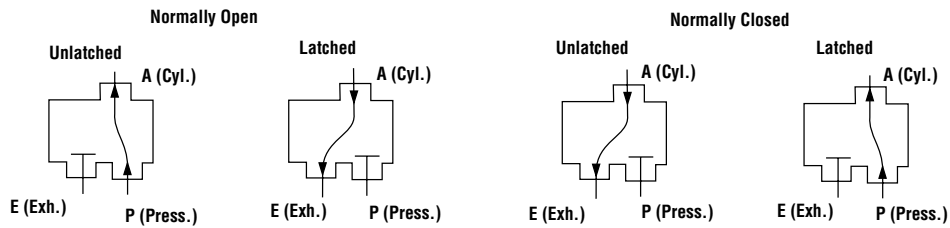

Free Handle Construction

Flow Diagram D

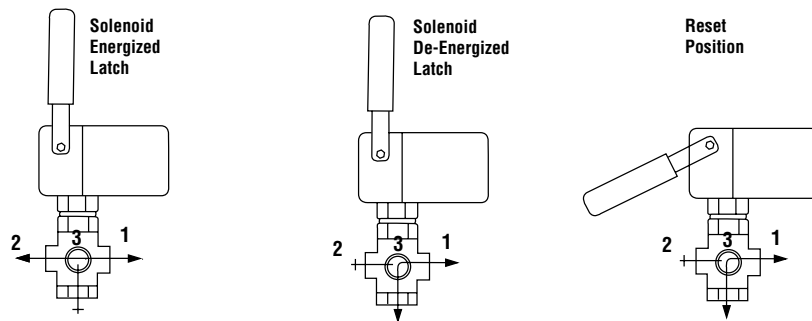

Flow Diagram E

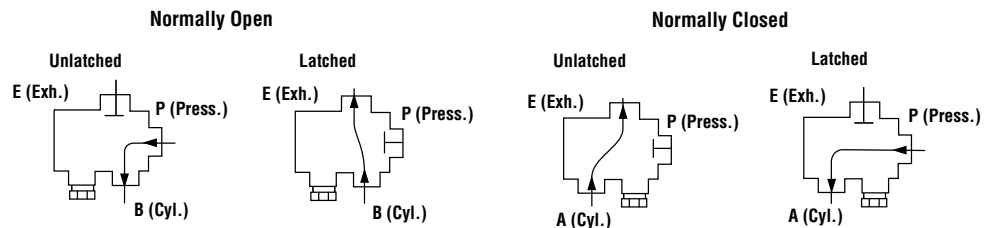

Dimensions: inches (mm)

Const. Ref. 1

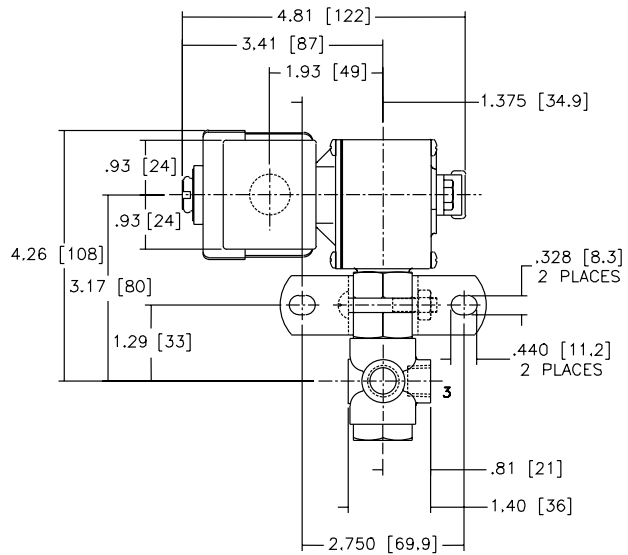
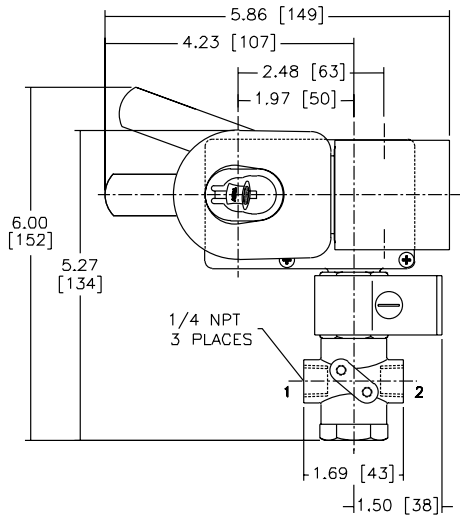

Const. Ref. 2

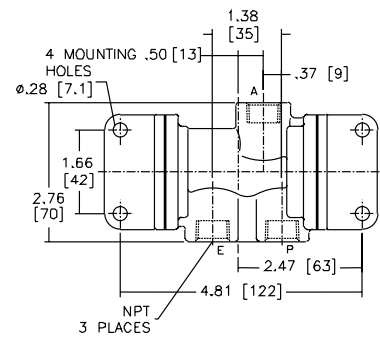
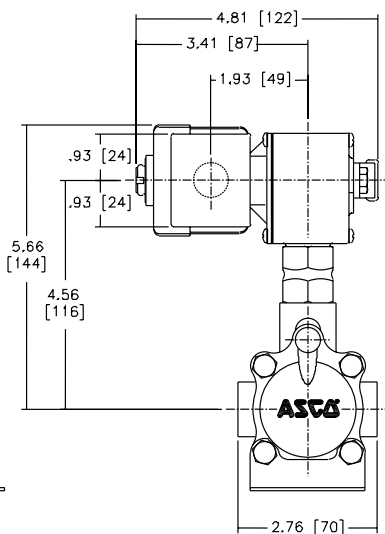
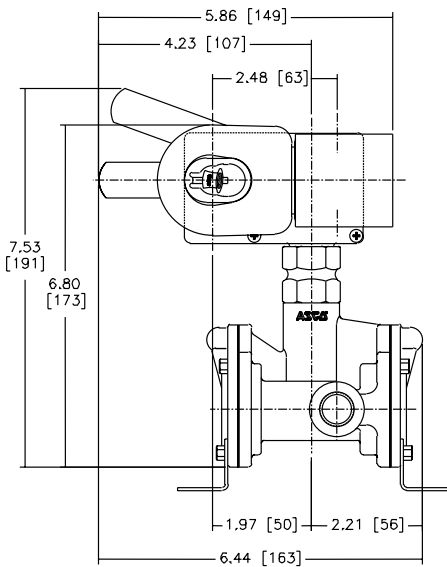

SPECIAL SERVICE
 PILOT

Dimensions: inches (mm)

Const. Ref. 3

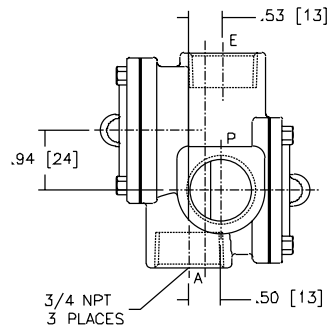
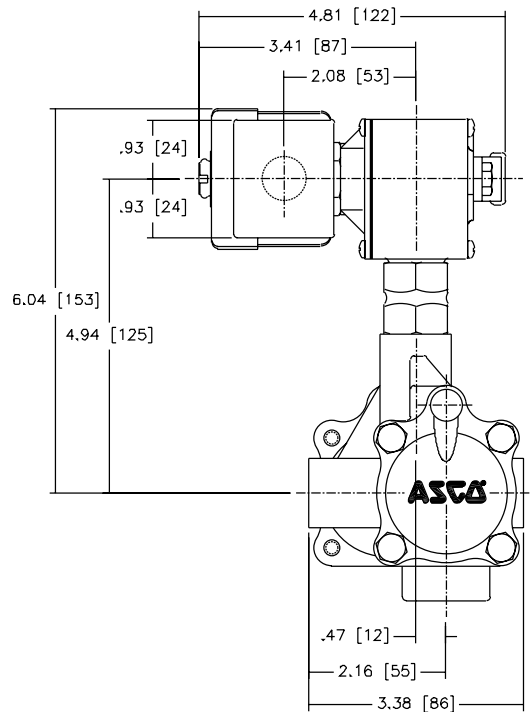
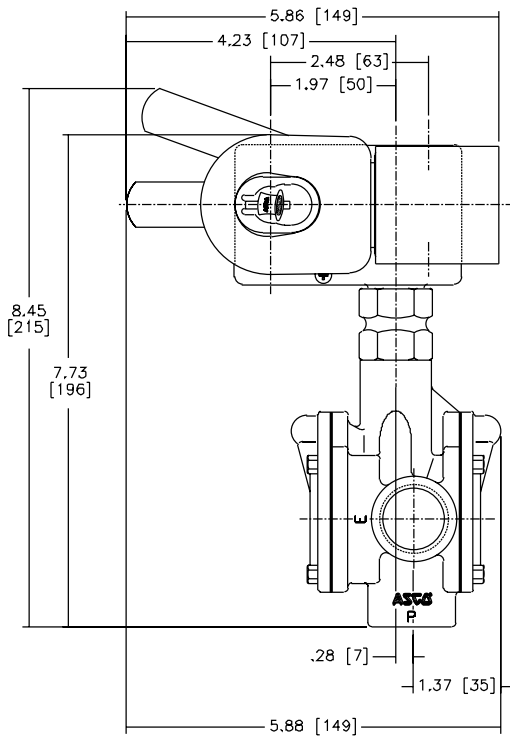

Dimensions: inches (mm)

Const. Ref. 4 ①

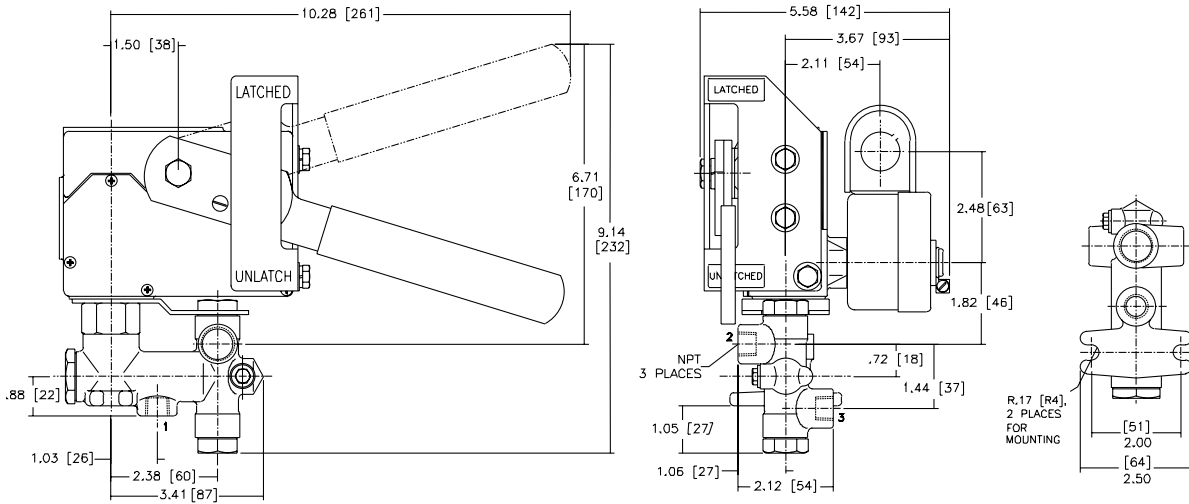

Const. Ref. 5 ①

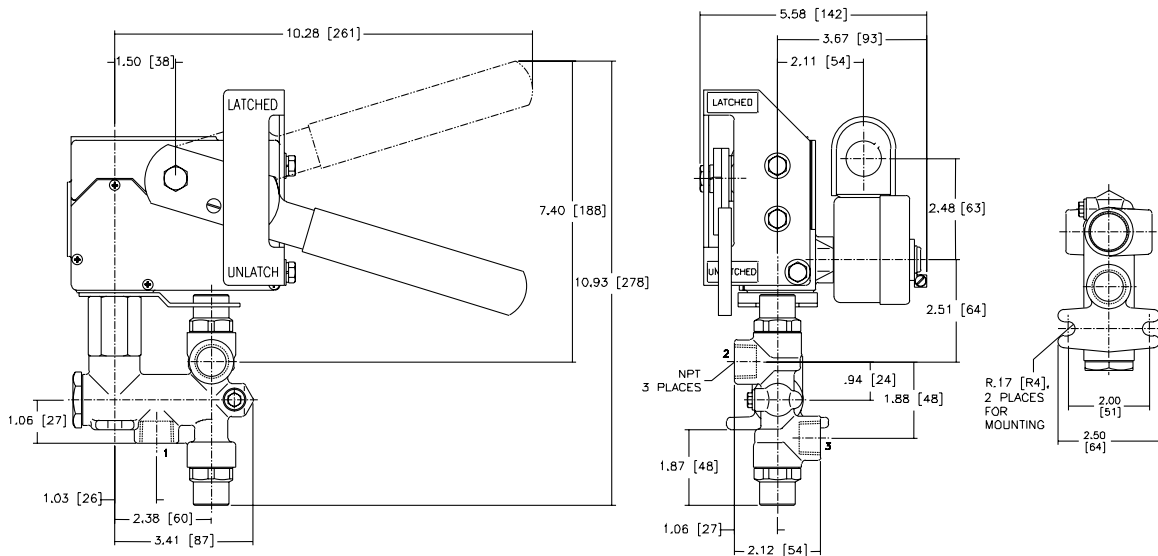

① **IMPORTANT: Valves must be mounted with manual reset operator vertical and upright.**

Dimensions: inches (mm)

Const. Ref. 6 ①

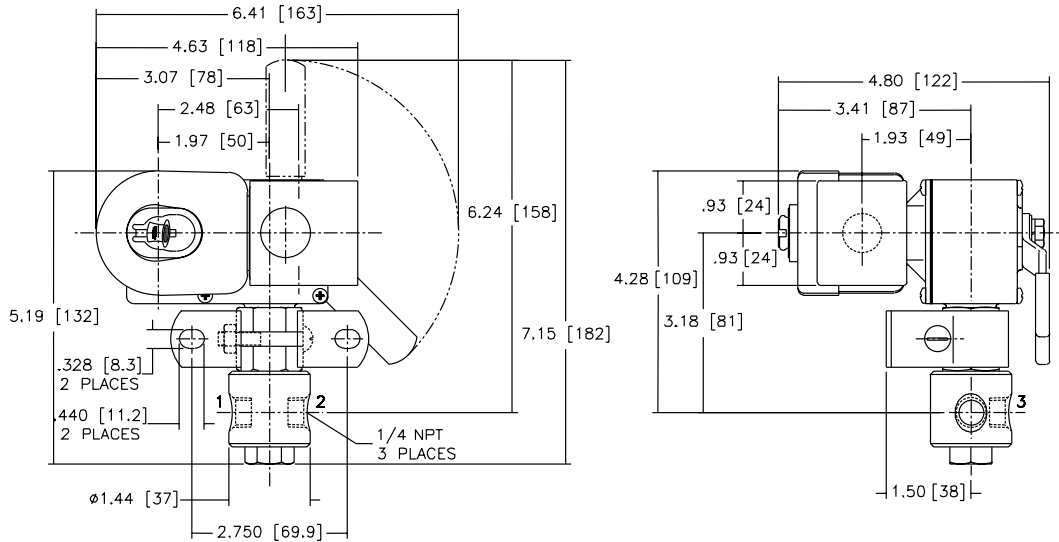

Const. Ref. 7 ①

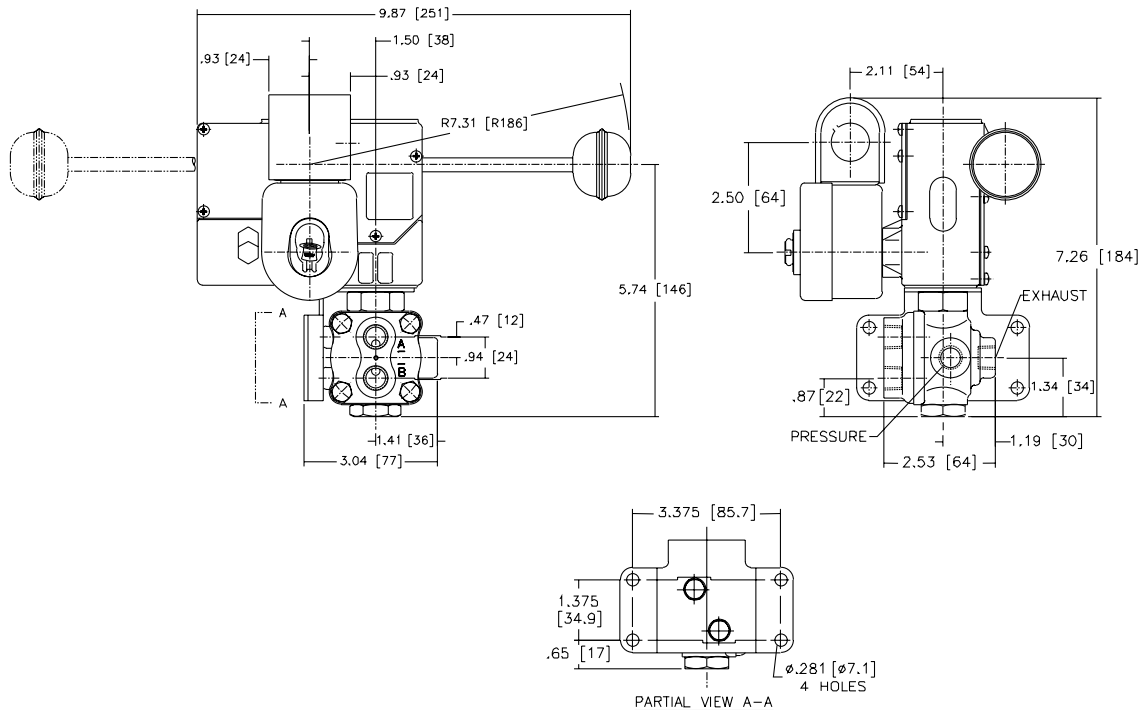

① IMPORTANT: Valves must be mounted with manual reset operator vertical and upright.

**SPECIAL SERVICE
PILOT**

Dimensions: inches (mm)

Const. Ref. 8

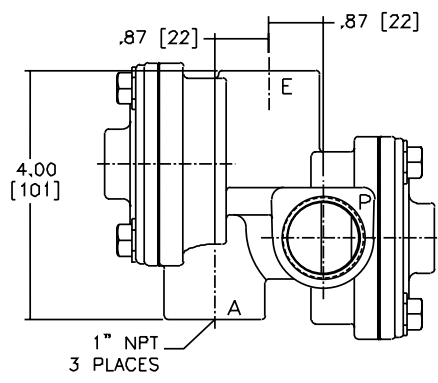
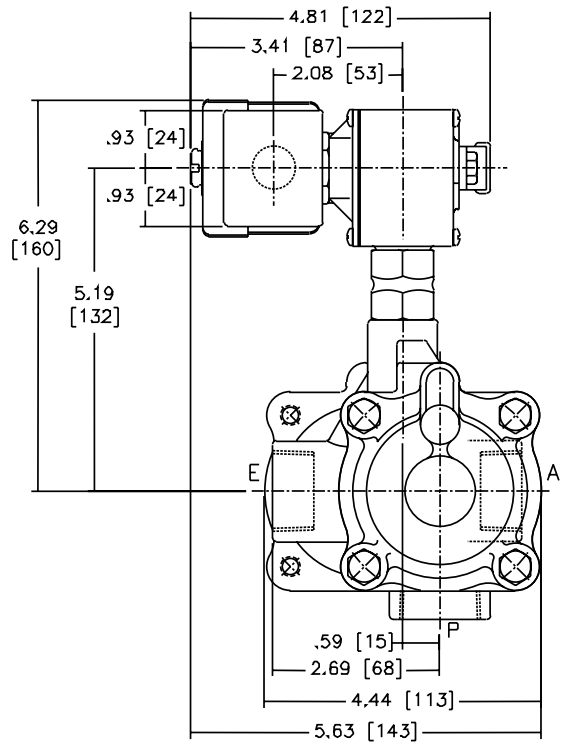
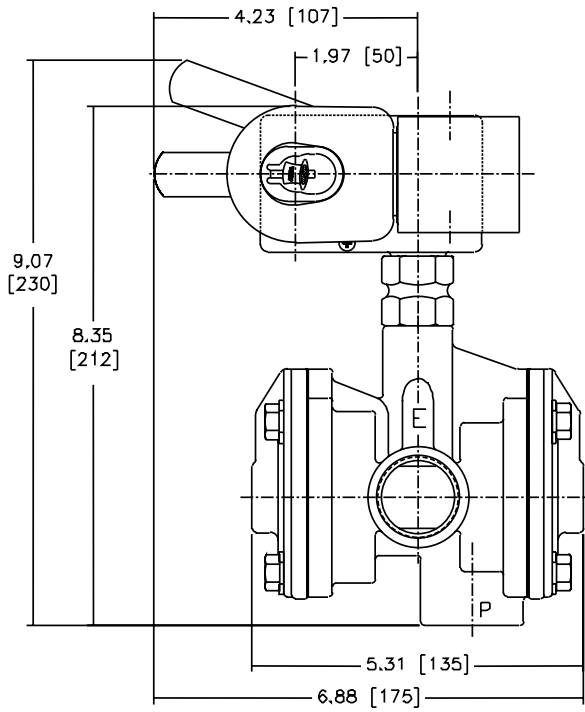

**SPECIAL SERVICE
 PILOT**